

## straight to the point

### The Fixturlaser® Shaft<sup>300</sup>\*

- 1 Robust aluminum case
- 2 Combined transmitter/detector units
- 1 Display unit with software
- 1 Laser transmitter T210
- 2 Chain fixtures
- 2 Magnet bases
- 2 TD fixtures
- 2 Cables
- 1 System Printer
- 1 Manual



### Accessories\*

- AC adapter
- Fixturlaser Documenter PC Software - Measurement result database
- Non-rotating shaft accessories
- Fixturlaser OL2R fixtures
- Cardan fixture
- Leatherette: Protection cover for the display unit
- Fixture for narrow spaces (10 mm)
- Upgrade packages



Fixturlaser® DU30, Display unit  
Handheld battery operated  
display unit with backlit icon  
based touch screen interface.



TD-M 100, Receiver unit  
Housing in precision  
moulded aluminum with  
built-in inclinometer.



T210, Laser transmitter  
Precision machined, hard  
anodized, housing with  
micrometer screws for fine  
adjustments. Detachable  
prism turret for 360° laser  
plane. Battery operated.

### Technical specification\*

Measuring distance	Up to 20 meters
Displayed measurement result resolution	0,001 mm
Operating temperature range	0-40°C
Detector size	20 x 20 mm
Power supply	Standard batteries, 4 x 1,5 volt
Operating time	Depending on operation cycle 10 - 20 hrs
Weight complete system	14,7kg

\* Specifications are subject to changes without notice.

Our representatives are all engineers and technicians with special knowledge and training in the latest measurement and alignment techniques. An extensive service programme

is provided to support all our customers. It includes telephone assistance, hardware repairs and software updates, as well as training and consultations regarding measurement applications.

FIXTURLASER AB  
Box 7  
SE-431 21 Mölndal  
Sweden  
Tel: + 46 31 706 28 00  
Fax: + 46 31 706 28 50  
Email: info@fixturlaser.se  
Web: www.fixturlaser.com



### The Fixturlaser® Shaft<sup>300</sup> system in short:

Icon based intuitive  
interface makes the  
system userfriendly

Fully upgradeable  
for future needs

Live values provide  
easy adjustments

Programs for  
measurement of car-  
dan shafts, machine  
trains, straightness  
and dynamic move-  
ments included

Measurement  
resolution down to  
0,001 mm

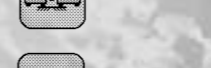
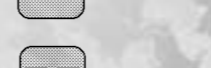
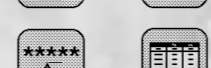

# FIXTURLASER® *Shaft<sup>300</sup>*

Fast, easy and precise mounting and positioning of rotating machines



### Fixturlaser Shaft<sup>300</sup> - the alignment tool for optimal mounting och positioning

Fixturlaser Shaft<sup>300</sup> is a laserbased alignment tool for mounting and positioning of rotating machinery. Fixturlaser Shaft<sup>300</sup> can not only be used for measuring, aligning and documenting the position of the machine shafts, but also for straightness and flatness measurement and alignment of machine foundations.

Foundations, base and sole plate conditions have a great impact on alignment of machines. If the foundation is skew, warped or affected by ground settings, it is very hard, if not impossible, to align machines to a satisfactory precision.

For businesses working within machine service, power generation and process industries, where large rotating machines can be found, Fixturlaser Shaft<sup>300</sup> is an optimal tool for fast, easy and precise shaft alignment.

Fixturlaser Shaft<sup>300</sup>, including a userfriendly and illustrative measurement function for flatness measurement



and alignment, can with advantage be used for alignment of machine shafts, machine foundations, machine flanges, large machine tables, forming tables and headboxes.

By adding the optional Fixturlaser OL2R fixtures for "off-line to running" measurements, you are able to compensate for dynamic movements in an easy and cost efficient way. Using the Fixturlaser OL2R fixtures with the Fixturlaser Shaft<sup>300</sup>, you will be able to measure cold to hot machine conditions, and vice versa. By measuring and compensating for dynamic movements, your shaft alignment will be as accurate as it can be in running condition. Combined with the Fixturlaser OL2R fixtures, Fixturlaser Shaft<sup>300</sup> is an ultimate shaft alignment tool.

## Measurement, Alignment and Documentation

The Fixturlaser Shaft<sup>300</sup> is an advanced alignment system providing functions for measuring and aligning machines, and for flatness measuring of machine bases.

The Fixturlaser Shaft<sup>300</sup> is an easy-to-use tool for the entire shaft alignment process, including pre-alignment functions, as well as memory and data transfer of results for full traceability.

## Touch Screen Technology

The user interface is entirely based upon icons and graphics. The touch sensitive screen provides the user with a clear and easily operated alignment tool displaying only the necessary information. The system is self intuitive and guides the user towards a perfect alignment result.

## Upgradeability

The Fixturlaser Shaft<sup>300</sup> can easily be upgraded adding more comprehensive functions, protecting your investment, and allowing you to upgrade it with future functions and developments, whenever your process requires it.

## Functions

The Fixturlaser Shaft<sup>300</sup> comes with the following functions:

- Shaft alignment of horizontal machines
- Shaft alignment of vertical machines
- Alignment of offset mounted machines/cardan shafts
- Alignment of machines with OL2R fixtures
- Machine train alignment
- Straightness measurement
- Flatness measurement
- Data communication
- Receiver display
- Memory management
- Repeatability test
- Thermal growth compensation
- Softcheck™ – soft foot measurement
- Feetlock™ - bolt-bound and base-bound solution
- Tripoint - alignment with limited rotation
- Tolerance table

Below you can read more about the functions of Fixturlaser Shaft<sup>300</sup>.

## Horizontal Shaft Alignment

Using the Fixturlaser Shaft<sup>300</sup> makes measurement, alignment and documentation easy. Just take three measurements by rotating the shafts. Then align against the live values shown on the display. The program guides you through the whole alignment process - step by step. Fast, easy and precise.

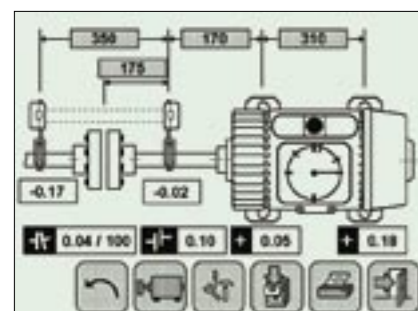

All values are continuously updated during adjustment, guiding the operator to a perfect alignment.

## Machine Train Alignment

Machine train alignment is a difficult and demanding task for an engineer. Often a machine train is part of a critical production, very expensive and the most costly to production loss when a machine breaks down. The most cumbersome part in aligning machine trains is to find out which machine to use as reference. With Fixturlaser Shaft<sup>300</sup>, the display screen guides you in finding the best solution in order to accomplish a perfect alignment.

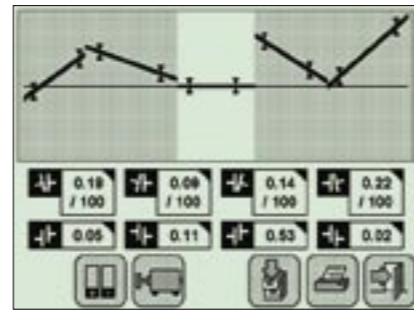
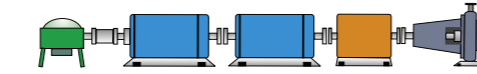

The most cumbersome part in aligning machine trains is to find out which machine to use as reference. The display screen guides you in finding the best solution in order to accomplish a perfect alignment.

## Vertical Shaft Alignment

Vertical machines are normally mounted with bolts on a flange instead of feet, which make the calculation of the correction values different from horizontal machines. The bolts may differ in numbers and are situated in a circle around the flange. The Shaft<sup>300</sup> can be used to measure and align vertically mounted and flange mounted machines. Results are presented with positions for each bolt. Fixturlaser Shaft<sup>300</sup> has made vertical alignment as easy as horizontal alignment. First, decide the number of bolts. After rotating the shafts to 9-12 positions, you will have the shims value displayed for each bolt. Adjust according to live values to correct the angular error as well as the offset for a perfect alignment.

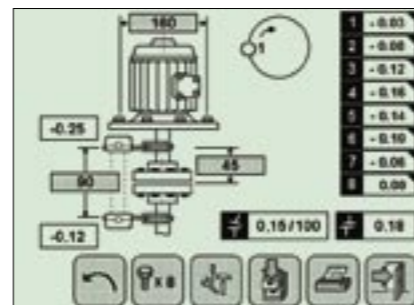

Vertical shaft alignment with Fixturlaser Shaft series. The result screen shows the current position of the motor and clearly advises necessary shimming.

## Straightness Measurements & Alignment

With the straightness program, you can measure the straightness of a shaft or the foundation. You can use up to sixteen measurement points. A reference point must be chosen. Adjust with the help of the live values presented on the display.

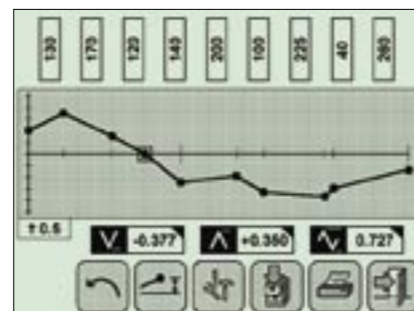

Fixturlaser Shaft<sup>300</sup> straightness program can measure, align and document up to 16 measurement points.

## Flatness Measurements and Alignment

Foundations, base and sole plate conditions have a great impact on alignment of machines. If the foundation is skew, warped or affected by ground settings, it is very hard to align machines to a satisfactory precision. Using the flatness measurement software in the Fixturlaser Shaft<sup>300</sup>, you can very quickly find out if the base fulfills the requirements.

Flatness can be measured in up to 121 points and the distance between the measurement points can be set to equal or individual. Adjustments can be made at each point with live values and the results stored for filing and traceability.

### Rectangular planes

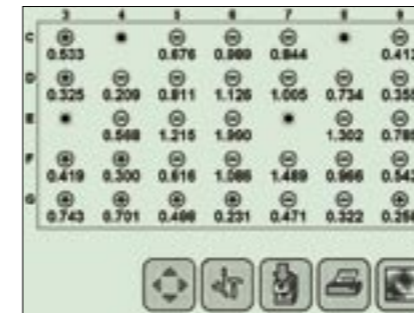

Flatness measurement results with Fixturlaser Shaft. The screen displays the status of the measurement points. The graphic with the user defined filter setting simplify the interpretation of the result. Each measurement point can be individually named and commented in the system.



### Circular planes

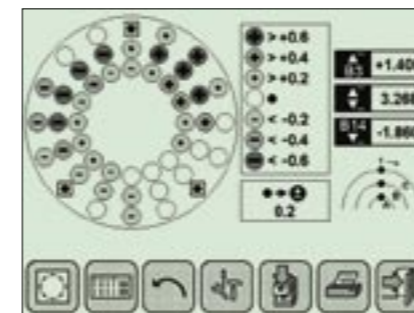

Flatness measurement, alignment and documentation of circular planes with Fixturlaser Shaft<sup>300</sup>. The Fixturlaser flatness program is illustrative and therefore easy-to-use.



## Documentation & Data Transfer

The documentation is an important part of the alignment procedure. Fixturlaser has made this part of the alignment process easy to use. You can save the measurements in the displaybox and name each measurement using up to 20 characters. All measurements can easily be filed and picked up again. The measurement data can also be transferred to a Windows based data base program, Fixturlaser Documenter and/or printed out.

With the fixtures for off-line to running and cardan shaft alignment, you are equipped with an ultimate shaft alignment tool:

## Off-line to Running Measurements

When performing alignment, you have to consider the change in the machine's relative position from static to running condition. Manufacturer specifications often consider thermal growth, due to rising temperature in the machine housing. Unfortunately, that is not enough to ensure good alignment in running mode. By introducing the Fixturlaser OL2R fixtures, Fixturlaser has made dynamic measurements easy and affordable. The Fixturlaser OL2R fixtures are e.g. mounted on a motor and a pump. Performing two measurements, one in offline mode and one in running mode, will give you the correction values for a precision alignment.

The machine will then be perfectly aligned during running mode.

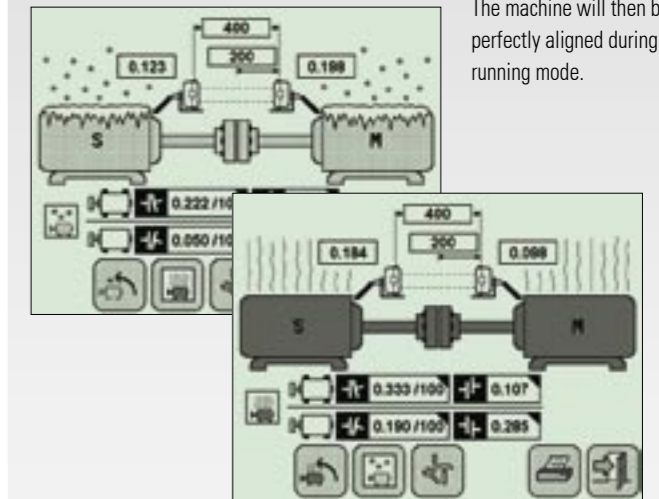

Machines move and grow from offline to running conditions. The Fixturlaser Shaft series have the capability to measure and calculate with these specific deviation values.

## Alignment of Offset Mounted Machines

Misaligned (angular misalignment) cardan shafts rotate with an uneven angular speed over a full turn. This generates vibrations with harmful forces throughout the drive chain. The risks with misaligned cardan shafts are similar to other misaligned machines plus the risks for damages caused by a broken cardan shaft.

By adding the Fixturlaser Cardan fixture, you will be able to align your cardan shafts. Fixturlaser Shaft<sup>300</sup>, together with the cardan shaft fixture make cardan shaft alignment as easy as normal horizontal shaft alignment. Here the angular error is of great importance. Live values will be displayed during the alignment process.

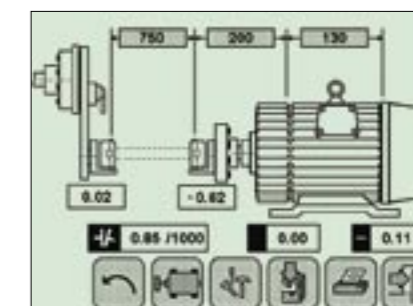

Alignment of offset mounted machines/cardan shafts follows the same procedure as for horizontal shaft alignment. The result screen tells us the position of the machine.